

NEW COOL LED MACHINE ILLUMINATION

Our **NEW** High Intensity

Ultraflex® **LED**

Waterproof Machine Light!



O.C. White Co.
Quality Since 1894

For any machine illumination application that demands the highest spot-light intensity as well as near limitless positioning possibilities while operating in the most challenging environments. Our new **10600/11600 LED Series** is designed to provide years of reliable service and we back them with our 3-year warranty. Fully sealed against the impingement of water, synthetic, and petroleum based fluids, the new 10600/11600 LED Series meets the stringent IP65 waterproof standards. Due to the rugged design, these fixtures are suitable for applications where extreme vibration shall be encountered. Our LED's provide 50,000+ hours of trouble free service.

Specifications

- 120V-277V AC, 50/60HZ (24V Available)
- 6 ft., 3 Prong Molded Cord
- Two Arm Styles Available
- High Output Energy Efficient 9W LED
- Light Output: 540 total lumens.
- "No Heat" High Intensity Spot Light
- Built-In Electronic Transformer
- Approvals: CE, IP65
- Mounting Options:
 - 600-CD (Clamp Mount)
 - 600-WM (Wall Mount)



LWL-10600-120

LWL-11600-120



600-WM
Wall Bracket Mount

WATER PROOF
IP65
UNDER PRESSURE



600-CD
Edge Clamp Mount

Technical Specifications

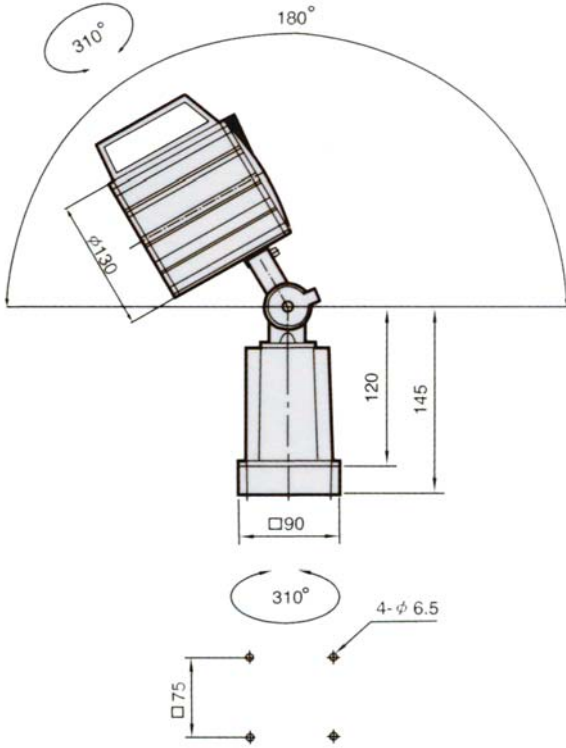

LWL-10600-120

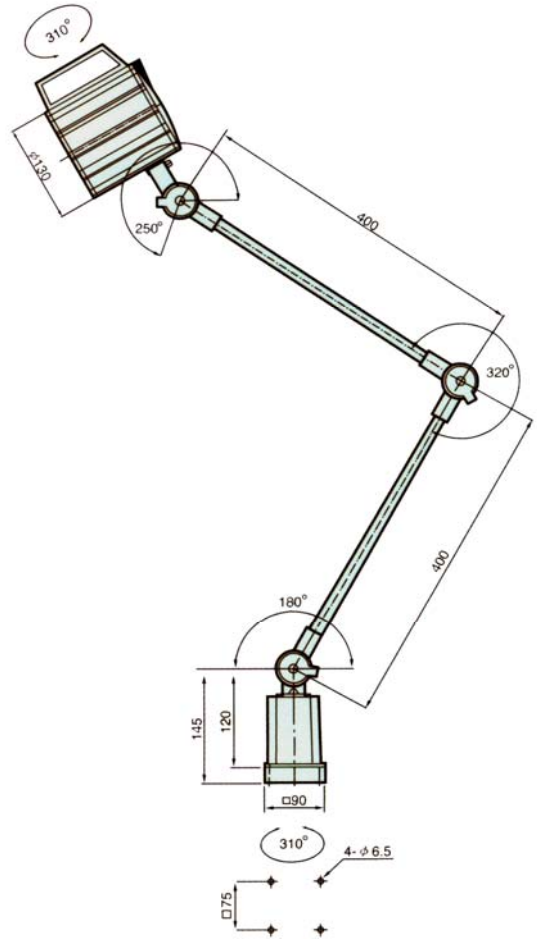

LWL-11600-120

**WATER PROOF
IP65
UNDER PRESSURE**

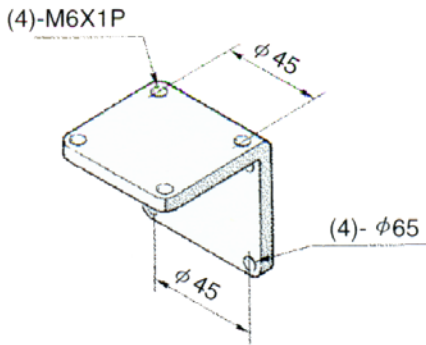

**600-WM
Wall Mount**

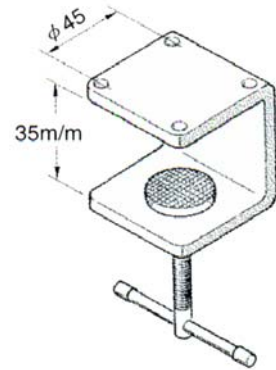

**600-CD
Edge Clamp Mount**

WHITE LITES®
O.C. White Co.
Quality Since 1894